

INSTALLATION

3. Camshaft pulleys

- Install camshaft pulleys and tighten bolts to the specified torque.

Torque	N·m (lb.ft.)	59 (43)
--------	--------------	---------

2. Timing belt

- Adjust timing belt as described in Timing belt installation.

1. Tension adjusting hole cover

- After the hole cover installation, install the right side engine mount and cylinder head cover by referring to each part's installation procedures.

TIMING BELT

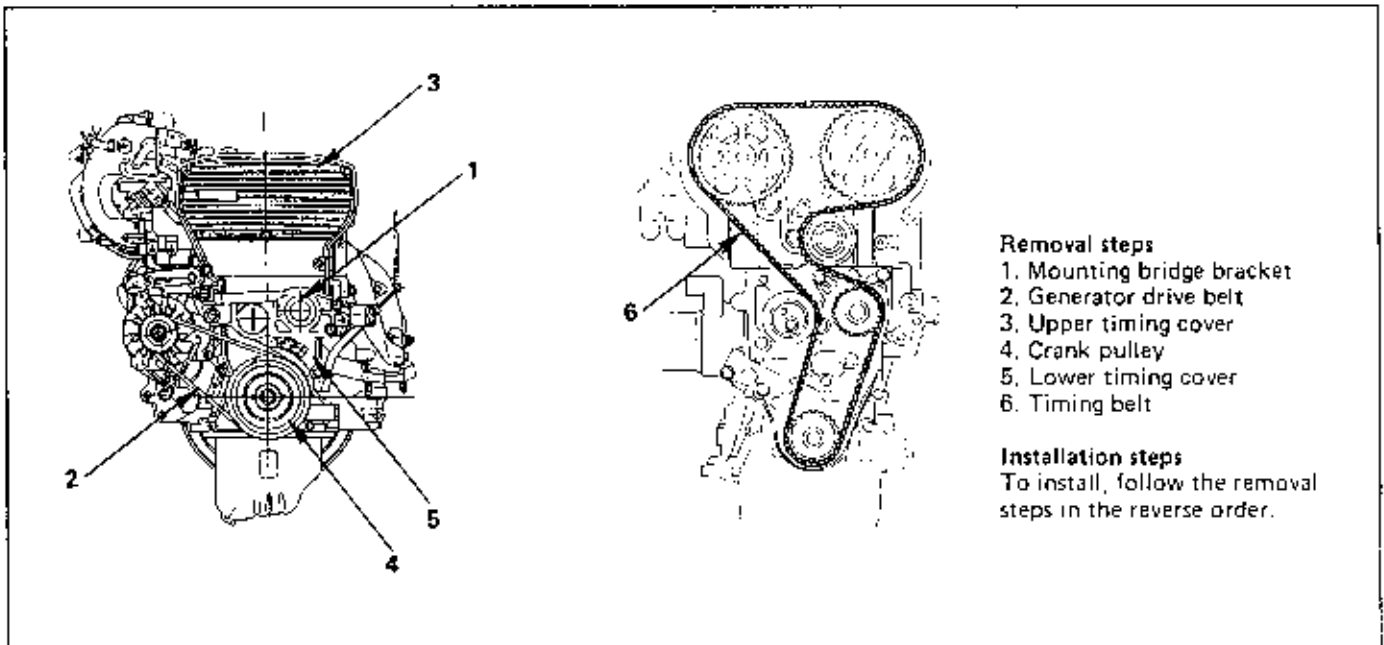

Fig. 6A2-22

REMOVAL

Preparation

- Battery ground cable.
- Support engine.
- Remove right side engine mounting.
- Remove power steering drive belt.

1. Mounting bridge bracket

2. Generator drive belt

3. Upper timing cover

4. Crank pulley

- Front exhaust pipe
- Torque rod bracket from cylinder block (Fig. 6A2-23).
- Torque rod center bolt and nut from center beam.
- Torque rod and bracket together.
- Stud from transmission housing.
- Stiffener (Fig. 6A2-24).
- Flywheel dust cover.
- Remove crank pulley bolt with locking flywheel ring gear and remove crank pulley.

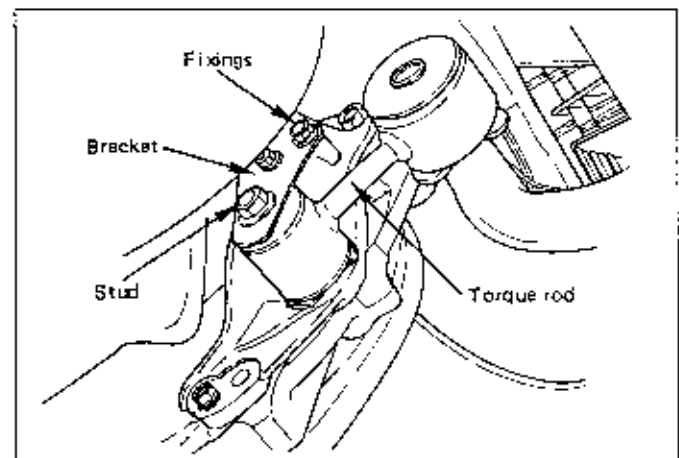

Fig. 6A2-23

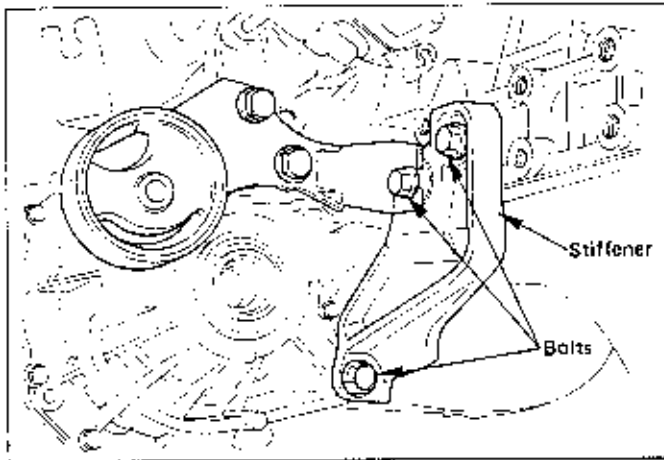

Fig. 6A2-24

5. Lower timing cover

6. Timing belt

- Reinstall crank pulley bolt and align crank timing pulley and camshaft pulley (Fig. 6A2-25, Fig. 6A2-26).
- Loosen tension pulley fixing bolt 1/2 turn (Fig. 6A2-27).
- Insert a hex wrench into tension pulley hexagonal hole and loosen timing belt by rotating tension pulley.
- Remove timing belt.

INSTALLATION

To install, follow the removal steps in the reverse order, noting the following adjustment procedures;

TIMING BELT ADJUSTMENT

CAUTION:

1. Do not bend or twist the belt. Severely twisting or bending the belt could damage the core. The belt should not be bent at a radius of less than 30 mm (1.2 in.).
2. Do not allow oil or other chemical substances to come in contact with the belt. These substances will shorten belt life.
3. Do not attempt to pry or stretch the belt with a screw driver or any other tool during the installation procedure.
4. Store timing belts in a cool and dark place. Never expose them to direct sunlight or heat.

1. Align camshaft pulley timing marks at TDC of No. 1 cylinder compression stroke (Fig. 6A2-26).
2. Lock camshaft pulley positioned by inserting 6 mm bolts through camshaft pulleys and into cylinder head (Fig. 6A2-28).
3. Align crankshaft timing pulley to TDC (Fig. 6A2-25).
4. Install the timing belt.

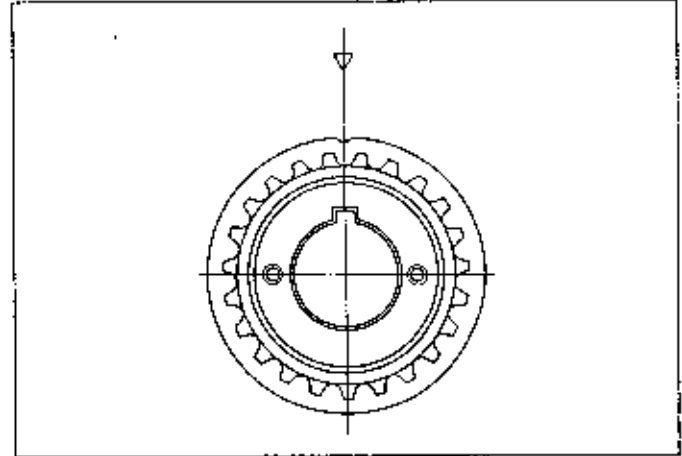

Fig. 6A2-25

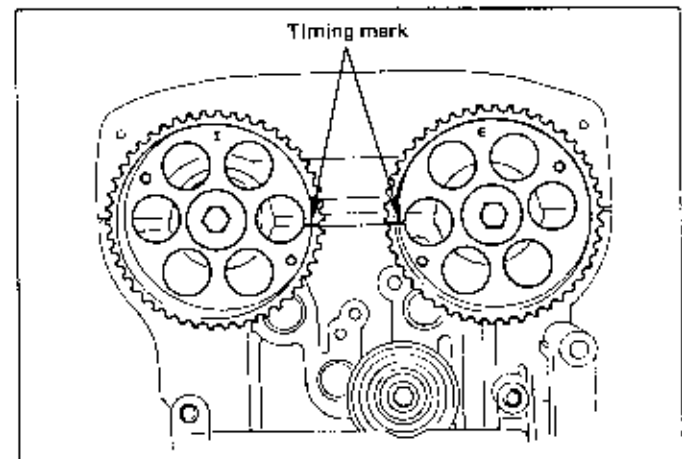

Fig. 6A2-26

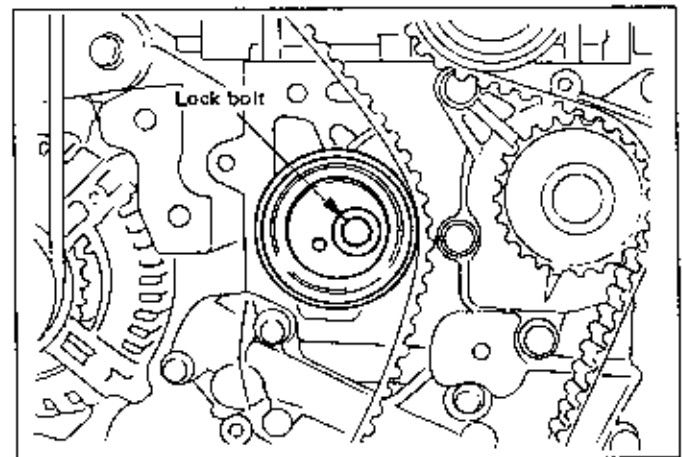

Fig. 6A2-27

NOTE:

To ensure the belt is installed correctly the lettering must be able to be read while viewing it from the passenger side fender (Fig. 6A2-29).

The belt must be installed in the following order (Fig. 6A2-30).

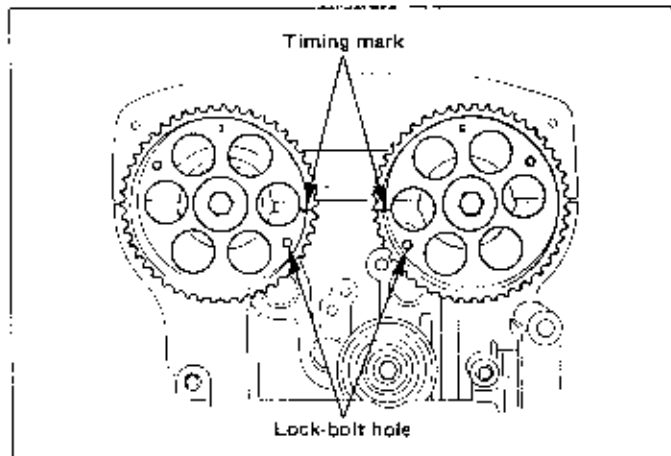

Fig. 6A2-28

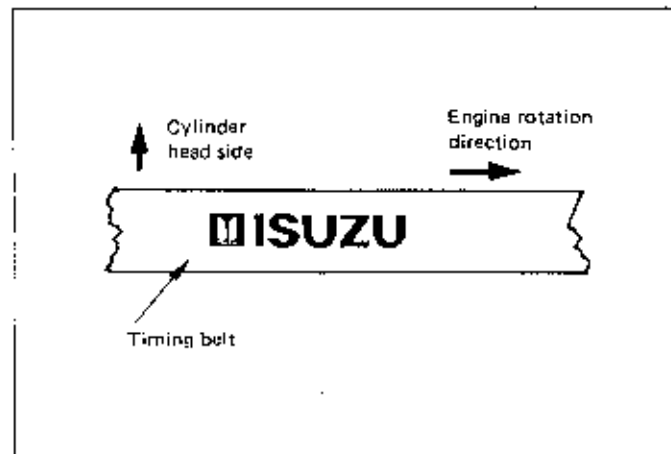

Fig. 6A2-29

- 1) Crankshaft timing pulley
- 2) Coolant pump pulley
- 3) Idle pulley
- 4) Exhaust camshaft pulley
- 5) Intake camshaft pulley
- 6) Tensioner pulley

NOTE:

There must be no slack in the belt after it has been installed. The teeth of the belt and the teeth of the pulley must be in perfect alignment.

5. Loosen the tensioner bolt and apply the spring force to the belt.

NOTE:

For reuse of the belt, do not tension the belt with other than the spring force applied. When a new belt is used, push the tension pulley in the direction of belt tension.

6. Tighten tensioner bolt to the specified torque.

	Torque	N-m (lb.ft.)	42 (31)
--	--------	--------------	---------

7. Rotate the crankshaft two turns and make sure that the crank timing pulley's mark and camshaft pulley's mark are correctly aligned.
8. Turn the crankshaft 60° and measure deflection of the belt as shown below. Make sure that it is within the specified range. If the deflection is not within the specified values, repeat the procedures from step 5.

Belt deflection at 98 N (22 lb.) (Fig. 6A2-31).

Deflection mm(in.)	New belt	7-8.5 (0.28-0.33)
	Used belt	9-10.5 (0.35-0.41)

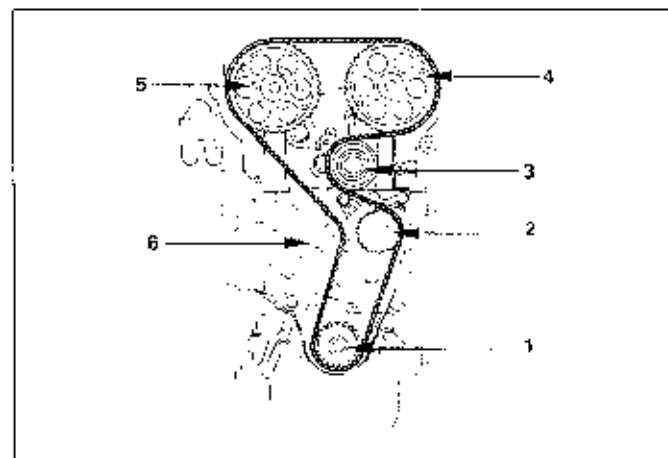

Fig. 6A2-30

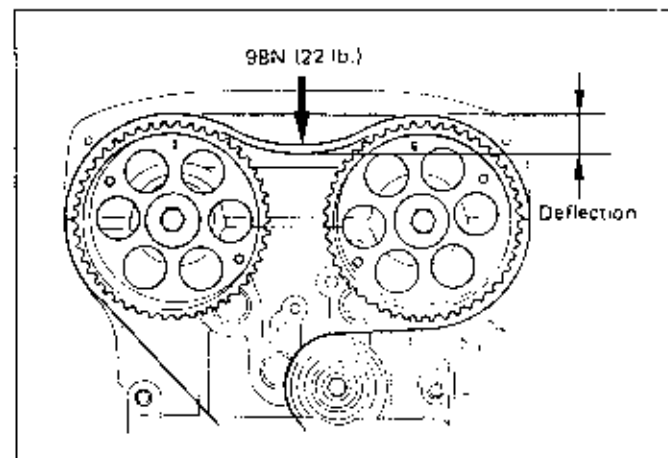

Fig. 6A2-31

9. Timing cover fixing bolts
 - Tighten to the specified torque.



Torque	N-m (lb.in.)	10 (89)
--------	--------------	---------

10. Crank pulley fixing bolt
 - Tighten to the specified torque.



Torque	N-m (lb.ft.)	147 (109)
--------	--------------	-----------